

WJEC (Eduqas) Chemistry A-Level

Practical Assessment Skills Essential Measurements

This work by [PMT Education](https://www.pmt.education) is licensed under [CC BY-NC-ND 4.0](https://creativecommons.org/licenses/by-nc-nd/4.0/)



Measuring Mass

The **before and after weighing method** (weighing-by-difference) is more accurate than weighing on a scale directly because it eliminates error from solid being left on the weighing boat. The weight of the material is the **difference between the two weights** of the weighing boat before and after you transfer the material from the weighing boat into the beaker. If the weighing boat weighs more than **0 g** after transfer, there are traces of solid left on the weighing boat. In the example of making a standard solution you should **wash** the weighing boat with distilled water.

Measuring Volume of Liquid

For identification tests, error in volume of liquid added is **not** significant. Therefore, using a dropping pipette or beaker is sufficient.

In **titrations**, a dropping pipette cannot be used because **volume in each drop varies**. For titrations a volumetric pipette should be used as per the diagram on the left. This is because the volumetric pipette can accurately measure a volume of 25 cm^3 to a very **high precision** (uncertainty is very low at $\pm 0.03\text{ cm}^3$).

Burettes or volumetric pipettes should be held vertically, as in the diagram, and the meniscus should be read at eye level to avoid **parallax error**. This ensures the exact volume has been measured.

In a titration you can **reduce** the **percentage error** in the volume of the titre by **increasing the volume** of the titre. This can be done by decreasing the concentration of what is being titrated, or increasing the volume of the liquid in the beaker.

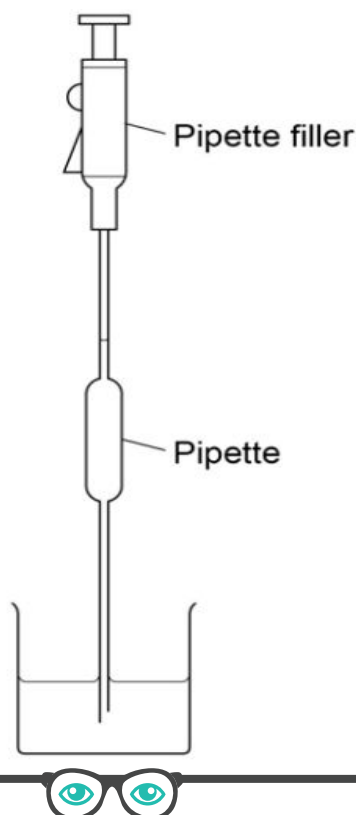

Measuring Volume of Gas

A gas syringe or water trough should be used to measure a volume of gas. The **syringe** is more easily operated but has a greater uncertainty than the **trough**. The measuring cylinder must be completely **full of water** before the beginning of the practical. The **meniscus** will fall on the volume of gas produced that collects at the top of the cylinder, giving a more precise volume than what is read in the syringe.

Gas Syringe Setup:

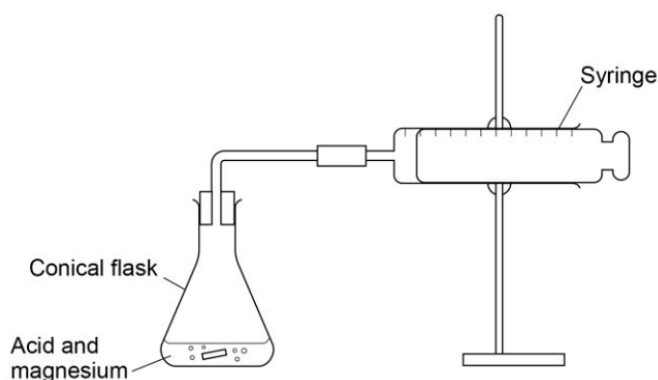

Water Trough Setup:

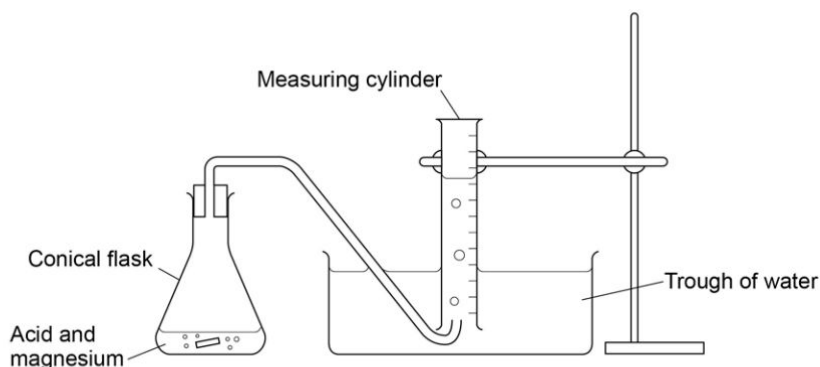

Measuring Temperature

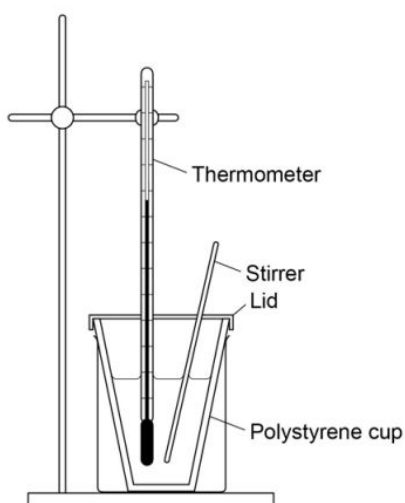

In an **enthalpy change** practical, the temperature change needs to be accurately measured. This is done by **minimising** heat loss or heat gain from the surroundings. A polystyrene cup and lid is used to **insulate** the reaction mixture from surroundings. The stirrer is used to ensure thermal energy is spread evenly in the reaction mixture. The bottom of the thermometer must be **in** the reaction mixture.

In required practical 5, distillation, the temperature must be measured at intervals to check that it is close to the liquid's boiling point. The thermometer needs to be at the top of the distillation column and the end **parallel to the start of the condenser tube** in order to measure the temperature of the vapors accurately.



Measuring pH

To reduce uncertainty, you must **stir** the solution and move the pH probe before reading to ensure that the H^+ concentration is **homogenous** in the solution. Also, you should construct a **pH calibration curve** before the acid-base titration. This is because the pH meter will most likely have a **systematic error** due to decalibration over time. This is done by measuring the read pHs of a known pH **buffers** and plotting on a calibration curve. The true pH of a read pH can then be read of the curve.

